

Article Info

Received: 01 Jan 2014 | Revised Submission: 20 Feb 2014 | Accepted: 28 Feb 2014 | Available Online: 15 Mar 2014

Automatic Irrigation System

Shagun Agarwal*, Suyash Pandey**, Shravan Kuma*** and Kunal Chaudhery****

ABSTRACT

Appropriate soil water level is a necessary pre-requisite for optimum plant growth. Also, water being an essential element for life sustenance, there is the necessity to avoid its undue usage. Irrigation is a dominant consumer of water. This calls for the need to regulate water supply for irrigation purposes. Fields should neither be over-irrigated nor under-irrigated. Over time, systems have been implemented towards realizing this objective of which automated processes are the most popular as they allow information to be collected at high frequency with less labor requirements. Bulk of the existing systems employ micro-processor based systems. These systems offer several technological advantages but are unaffordable, bulky, difficult to maintain and less accepted by the technologically unskilled workers in the rural scenario.

Keywords: Microcontroller; PIC17F877; Soil Moisture Sensor.

1.0 Introduction

Weather is thunderstorms, tropical depressions, tornados, blizzards, squall lines, stationary fronts, cold fronts from Canadian, warm moist Gulf air, and hurricanes. The onset of any one of these events can be detected by monitoring a few basic conditions. When you check the weather on the television or the radio, it's always what conditions are like at the airport or some other remote location. But, what are conditions like in my backyard? To address this, I embarked on the design of the Weather Station. We are doing development of low-cost water monitoring system in soil consisting of soil moisture level sensor.

For sensing level of soil moisture we have used famous and efficient probes. It is a circuit sensor that can be used to measure soil moisture with an electrical output proportional to the water in soil. And with increase and decrease in soil moisture level in the soil we are controlling it through motor pump which will exact the water in/out when it will sense decrease in soil moisture and vice versa.

2.0 Block Diagram

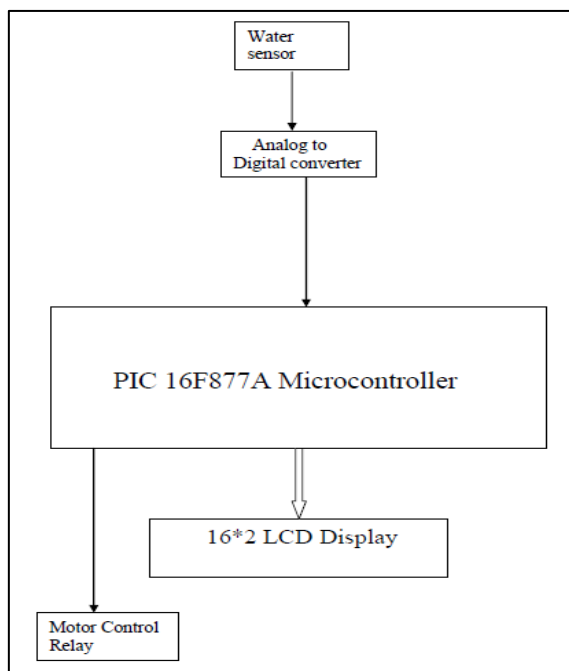

*Corresponding Author: Department of Electrical and Electronics Engineering, MIT, Moradabad, Uttar Pradesh, India (E-mail: agarwalshagun01@gmail.com)

**Department of Electrical and Electronics Engineering, MIT, Moradabad, Uttar Pradesh, India

***Department of Electrical and Electronics Engineering, MIT, Moradabad, Uttar Pradesh, India

****Department of Electrical and Electronics Engineering, MIT, Moradabad, Uttar Pradesh, India

3.0 Working

(A) Microcontroller-The brain of our project is PIC17F877 microcontroller. PIC16F877 belongs to a class of 8-bit microcontrollers of RISC architecture. It has 8kb flash memory for storing a written program. Since memory made in FLASH technology can be programmed and cleared more than once, it makes this microcontroller suitable for device development.

IT has data memory that needs to be saved when there is no supply. It is usually used for storing important data that must not be lost if power supply suddenly stops. For instance, one such data is an assigned temperature in temperature regulators.

If during a loss of power supply this data was lost, we would have to make the adjustment once again upon return of supply. PIC16F877 belongs to a class of 8-bit microcontrollers of RISC architecture. It has 8kb flash memory for storing a written program. Since memory made in FLASH technology can be programmed and cleared more than once, it makes this microcontroller suitable for device development.

IT has data memory that needs to be saved when there is no supply. It is usually used for storing important data that must not be lost if power supply suddenly stops. For instance, one such data is an assigned temperature in temperature regulators. If during a loss of power supply this data was lost, we would have to make the adjustment once again upon return of supply.

B) Power supply: The power supply section consists of step down transformers of 230V primary to 12V secondary voltages for the +5V power supplies respectively.

The stepped down voltage is then rectified by 4 1N4007 diodes. The high value of capacitor 1000 μ F charges at a slow rate as the time constant is low, and once the capacitor charges there is no resistor for capacitor to discharge.

This gives a constant value of DC. IC 7805 is used for regulated supply of +5 volts in order to prevent the circuit ahead from any fluctuations. The filter capacitors connected after this IC filters the high frequency spikes. These capacitors are connected in parallel with supply and common so that spikes filter to the common. These give stability to the power supply circuit.

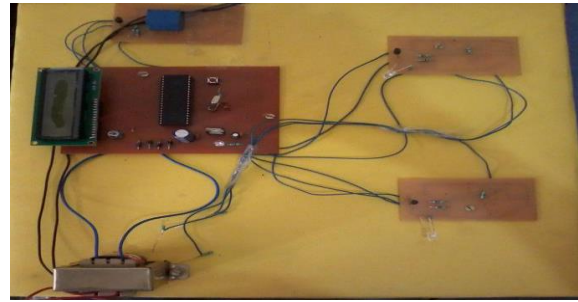

As can be seen from the above circuit diagrams, the rectified voltage from the 4 diodes is given to pin 1 of the respective regulators. Pin 2 of the regulators is connected to ground and pin 3 to Vcc. With adequate heat sinking the regulator can deliver 1A output current. If internal power dissipation becomes too high for the heat sinking provided, the thermal shutdown circuit takes over preventing the IC from overheating.

C) Soil moisture sensor: This sensor is based on the fact that water is not pure water which is non-conductor, but it is impure which is slightly conductor.

Water sensor is nothing but a series of very close PCB tracks. In normal mode these tracks are not conducting, but when some water fall on these tracks these line slightly start conducting and some positive voltage is available at the base of transistor So NPN transistor is on and NPN transistor provide a negative voltage as a pulse to the microcontroller. The output voltage of a sensor is amplified by an operational amplifier, and is inputted into the base of transistor The moisture sensitivity adjusting the gain of an operational amplifier by VR.

D) Display section: The display section consists of 16*2 LCD, which used to display Summary vehicle status. LCDs can add a lot to your application in terms of providing an useful interface for the user, debugging an application or just giving it a "professional" look. The most common type of LCD controller is the Hitachi 44780 which provides a relatively simple interface between a processor and an LCD.

The LCD interface is a parallel bus, allowing simple and fast reading/writing of data to and from the LCD. This waveform will write an ASCII Byte out to the LCD's screen. The ASCII code to be displayed is eight bits long and is sent to the LCD either four or eight bits at a time. If four bit mode is used, two "nybbles" of data (Sent high four bits and then low four bits with an "E" Clock pulse with each nibble) are sent to make up a full eight bit transfer.

The "E" Clock is used to initiate the data transfer within the LCD. Sending parallel data as either four or eight bits are the two primary modes of operation. While there are secondary considerations and modes, deciding how to send the data to the LCD is most critical decision to be made for an LCD interface application.

Eight bit mode is best used when speed is required in an application and at least ten I/O pins are available. Four bit mode requires a minimum of six bits. To wire a microcontroller to an LCD in four bit mode, just the top four bits (DB4-7) are written to. The "R/S" bit is used to select whether data or an instruction is being transferred between the microcontroller and the LCD. If the Bit is set, then the byte at the current LCD "Cursor" Position can be read or written.

When the Bit is reset, either an instruction is being sent to the LCD or the execution status of the last instruction is read back (whether or not it has completed).

4.0 Pin Description

Pins	Description
1	Ground
2	Vcc
3	Contrast Voltage
4	"R/S" _Instruction/Register Select
5	"R/W" _Read/Write LCD Registers
6	"E" Clock
7 - 14	Data I/O Pins
15-16	LED + LED

5.0 Circuit Diagram

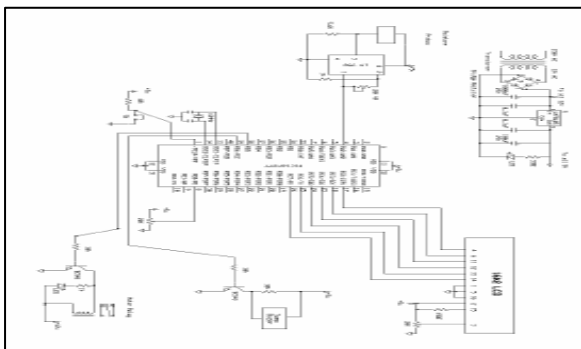

6.0 Conclusion

A methodological approach has been followed in designing the opamp based system for measurement and control of the plant growth parameter, i.e. soil moisture. The results obtained from the measurement have shown that the system performance is quite reliable and accurate.

Field experience has shown that soil moisture sensors are very useful in diagnosing the changes needed and to fine-tune irrigation practices. Relatively minor regulations in irrigation practices can pay large dividends in terms of increased yields or water savings. The key to proper irrigation management using soil moisture sensors is regular monitoring of the sensors to track the soil moisture level and provide irrigation when the readings are in the determined range for the particular soil type.

References

- [1] Louis Nashelsky, Robert L. Boylestad (1997). Electronic Devices and Circuit Theory 6 Edition, p. 822. Prentice-Hall, India.
- [2] `Scott MAC. Kenzie, The 8051 micro controller, second edition, pretice hall Inc., USA, (1995).John B Peatmen, Design with micro controllers, Mc- Graw Hill, USA.
- [3] <http://www.mikroe.com/chapters/view/74/pic-basic-book-chapter-1-world-of-microcontrollers>
- [4] M.A. Mazidi & J G mazidi, The 8051 micro controller and embedded systems, pearson education asia (2002)s